



SUPERCAPACITOR AUTO BALANCING PCB

GENERAL DESCRIPTION

The SABMB16 is a universal Printed Circuit Board (PCB) designed to be used with the entire ALD8100xx and ALD9100xx family of SAB MOSFETs for system designers and application developers. SAB MOSFETs are ALD exclusive EPAD® MOSFETs designed to address leakage and voltage balance of supercapacitor cells connected in series. SAB MOSFETs and the SABMB16 boards are designed to be compact, economical and effective in balancing any size supercapacitors with little or no additional power dissipation.

Supercapacitors, also known as ultracapacitors, when connected two, three or four cells in series can be balanced with ALD8100xx/ALD9100xx packages installed on the SABMB16 board. Supercapacitors, when connected more than four cells in series, can be balanced with more than one SABMB16 board (each with ALD8100xx/ALD9100xx packages installed) connected in series.

SABMB16 is designed to be easy and ready to use as a plug-and-play PCB, whether for developmental prototyping, demonstration and evaluation, or production deployment purposes. It is suited for balancing supercapacitor stacks ranging from two in series to hundreds in series, and for supercapacitors of 0.1F to 3000F and beyond. The average additional power dissipation due to use of SABMB boards is zero, which makes this method of supercapacitor balancing very energy efficient, especially suited for low loss energy harvesting and long life battery operated applications.

SABMB16 is a blank PCB, ready for ALD8100XX or ALD9100xx to be installed. SABMB810025 is a SABMB16 with one ALD810025SCLI installed and tested. SABMB910025 is a SABMB16 with two ALD910025SALI installed and tested. These are rated for industrial temperature of -40°C to +85°C.

ORDERING INFORMATION

Part Number	Description
SABMB16	Blank Universal PCB
SABMB810025	SABMB16 Board with one ALD810025SCLI
SABMB910025	SABMB16 Board with two ALD910025SALI
SABMB8100XX	SABMB16 Board with one ALD8100XXSCLI
SABMB9100XX	SABMB16 Board with two ALD9100XXSALI

Note: SABMB8100XX/SABMB9100XX are optional with specified ALD8100XXSCLI or ALD9100XXSALI units installed. Minimum order quantity (MOQ) requirements may apply. XX = 16,17,18,19,20,21,22,23,24,26,27,28
See page 4 for full listing of part numbers.

The SABMB16 board is designed with the following additional features for flexibility in a variety of different applications:

- 1) One or two ALD9100xx dual SAB MOSFET units installed per board.
- 2) One ALD8100xx quad SAB MOSFET unit installed per board.
- 3) Two ALD9100xx and one ALD8100xx can be installed on the same SABMB16 board. The two ALD9100xx are connected in series whereas the ALD8100xx are connected in parallel to the two ALD9100xx units.
- 4) Optional R1 and R2 resistors can be installed with values ranging from open circuit to 0 Ω.
- 5) Optional reverse biased external power diodes (schottky rectifiers) can be installed, where necessary, across each SAB MOSFET.
- 6) Each SABMB16 PCB can be cascaded to the next SABMB16 PCB to form a series chain to parallel a series-connected chain of supercapacitor cells.
- 7) Compact size of 0.6 in. by 1.6 in. with mounting holes
- 8) Rated for RoHS compatible/industrial temperature range of -40°C to +85°C

MECHANICAL DRAWING

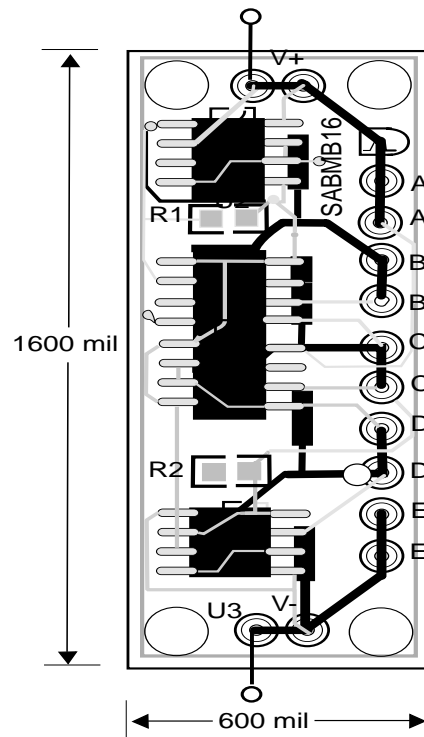

SUPERCAPACITOR AUTO BALANCING PCB

The ALD8100XX/ALD9100XX SAB MOSFET family offers the user a selection of different threshold voltages for various supercapacitor nominal voltage values and desired leakage balancing characteristics. Each SAB MOSFET generally requires connecting its V+ pin to the most positive voltage and its V- and IC pins to the most negative voltage within the package. Note that each Drain pin has an internal reverse biased diode to its Source pin, and each Gate pin has an internal reverse biased diode to V-. All other pins must have voltages within V+ and V- voltage limits within the same package unit. Standard ESD protection facilities and handling procedures for static sensitive devices must also be used while installing the ALD8100XX or ALD9100XX units. Once installed, the connection configuration will protect the ALD8100XX/ALD9100XX units from ESD damage. When connected to a supercapacitor stack, the ALD8100XX/ALD9100XX is further protected from virtually any ESD damage due to the large capacitance of the supercapacitors, which sinks any ESD charge and thereby reduces any of the terminal voltages to minimal harmless values.

SABMB16 PRINTED CIRCUIT BOARDS

The SABMB16 Printed Circuit Board is supplied as a blank PCB board, made with RoHS compliant FR4 material, ready for mounting of up to two 8-lead ALD9100XX units or one 16-lead ALD8100XX unit. It is also supplied and available with a 6 digit suffix, which denotes the specific ALD9100XX or ALD8100XX component mounted and tested on the PCB. All that is required for the user to perform is mount the PCB and wire the appropriate connections from the SABMB16 board to the respective supercapacitor nodes.

Each SABMB16 Printed Circuit Board has two 8-lead SOIC footprints for up to two ALD9100XX units. It also has a 16-lead SOIC footprint for an ALD8100XX which is parallel connected to the two ALD9100XX footprints (See schematic diagram). Each SABMB16 PCB has terminals labeled V+, A, B, C, D, E and V-. Each of these terminals has two wiring holes for easier connection of the same terminal node to two external connection points. V+ is directly connected to terminal A, which must be connected to the most positive voltage for the individual SABMB16 PCB board. V- is directly connected to terminal E, which must be connected to the most negative voltage present for the same SABMB16 board. All other terminals, namely B, C and D, must have voltages between V+ and V- for the board. When cascade or daisy-chain connected, each SABMB16 board is self-contained and rated for 15.0V maximum.

When two supercapacitors are installed to be balanced by SAB MOSFETs, a single ALD9100XX unit can be mounted on either one of two 8-lead SOIC footprints on the SABMB16. The user then needs to connect the unused circuit traces to the appropriate terminals so that V+ and V- remain the most positive voltage and the most negative voltage for that SABMB16 board, respectively. For example, if only one ALD9100XX is used for the upper SOIC footprint, terminal C can be connected to terminal E, or V-. One convenient way to make this connection on board is to install R2 with a value equal to $0\ \Omega$ or use an external wire.

Any number of SABMB16 boards can be daisy-chain connected in series. For example, three SABMB16 boards, each with an

ALD810025SCLI installed, can be connected in series to a 30V power supply, provided care is taken to insure that each SABMB16 board V- is connected to the V+ of the next SABMB16 board in series, such that each board would not have internal voltages from V+ to V- exceeding 10V ($30V/3 = 10V$).

The ALD8100XX/ALD9100XX is rated for reverse bias diode currents of up to 80 mA maximum for each SAB MOSFET on board. Any reverse bias condition as a result of changing supercapacitor voltages, especially during fast supercapacitor discharge, could lead to some internal nodes temporally reverse biased with surge current in excess of this limit. The SABMB16 board has additional optional TO277 footprints for mounting external schottky rectifiers (power diodes) to clamp such current transients. The user is advised to determine the various power and current limits, including temperature and heat dissipation considerations, when selecting a suitable component for such purpose. The appropriate level of derating and margin allowance must also be added to assure long term reliability of the PCB board.

SUPERCAPACITORS

Supercapacitors are typically rated with a nominal recommended working voltage established for long life at their maximum rated operating temperature. Excessive supercapacitor voltages that exceed its rated voltage for a prolonged time period will result in reduced operating life and eventual rupture and catastrophic failure. To prevent such an occurrence, a means of automatically adjusting (charge-balancing) and monitoring the maximum voltage is required in most applications having two or more supercapacitors connected in series, due to their different internal leakage currents that vary from one supercapacitor to another.

The supercapacitor leakage current itself is a variable function of its many parameters such as aging, initial leakage current at zero input voltage, the material and the construction of the supercapacitor. Its leakage is also a function of the charging voltage, the charging current, operating temperature range and the rate of change of many of these parameters. Supercapacitor balancing must accommodate these changing conditions.

ENERGY HARVESTING APPLICATIONS

Supercapacitors offer an important benefit for energy harvesting applications from a low energy source, buffering and storing such energy to drive a higher power load.

For energy harvesting applications, supercapacitor leakage currents are a critical factor, as the average energy harvesting input charge must exceed the average supercapacitor internal leakage currents in order for any net energy to be harvested and saved. Often, the input energy is variable, meaning that its input voltage and current magnitude are not constant and may be dependent upon a whole set of other parameters such as the source energy availability, energy sensor conversion efficiency, etc.

SAB MOSFETs used for charge balancing, due to their high input threshold voltages, would be completely turned off, consuming zero drain current while the supercapacitor is being charged,

SUPERCAPACITOR AUTO BALANCING PCB

maximizing any energy harvesting gathering efforts. The SAB MOSFET would not become active until the supercapacitor is already charged to over 90% of its max. rated voltage. The trickle charging of supercapacitors with energy harvesting techniques tends to work well with SAB MOSFETs as charge balancing devices, as it is less likely to have high transient energy spurts resulting in excessive voltage or current excursions.

If an energy harvesting source only provides a few μA of current, the power budget does not allow wasting any of this current on capacitor leakage currents and power dissipation of resistor or operational amplifier based charge-balancing circuits. It may also be important to reduce long term leakage currents, as energy harvesting charging at low levels may take up to many days.

In summary, in order for an energy harvesting application to be successful, the input energy harvested must exceed all the energy required due to the leakages of the supercapacitors and the charge-balancing circuits, plus any load requirements. With their unique balancing characteristics and near-zero charge loss, SAB MOSFETs are ideal devices for use in supercapacitor charge-balancing in energy harvesting applications.

BATTERY POWERED APPLICATIONS

Many battery powered circuits that also require supercapacitor at its output to boost power output can benefit from using SAB MOSFETs for supercapacitor balancing. As previously described, the additional power burn by using SAB MOSFETs for supercapacitor stack balancing can be negative, meaning that adding SAB MOSFETs can not only not burn extra power, but can actually save supercapacitor leakage current and associated power dissipation. Applications that depend on long life battery usage must take into account the supercapacitor leakage current and balancing circuit power burn because the currents involved are steady state DC currents that are continuous throughout the lifetime of the application and its battery life. The average power dissipation of addition of SABMB16 board is zero, provided the selection of the operating voltages and SAB MOSFETs are appropriate for the leakage currents of the supercapacitors specified.

For more information on the CHARACTERISTICS OF SUPERCAPACITOR AUTO BALANCING (SAB^a) MOSFETS, please refer to the document:

ALD8100XX/ALD9100XX FAMILY of SUPERCAPACITOR AUTO BALANCING (SABTM) MOSFET ARRAYS and individual datasheet of each of the SAB MOSFETs.

SABMB16 PCB CONNECTION TO SUPERCAPACITORS C1, C2, C3, C4

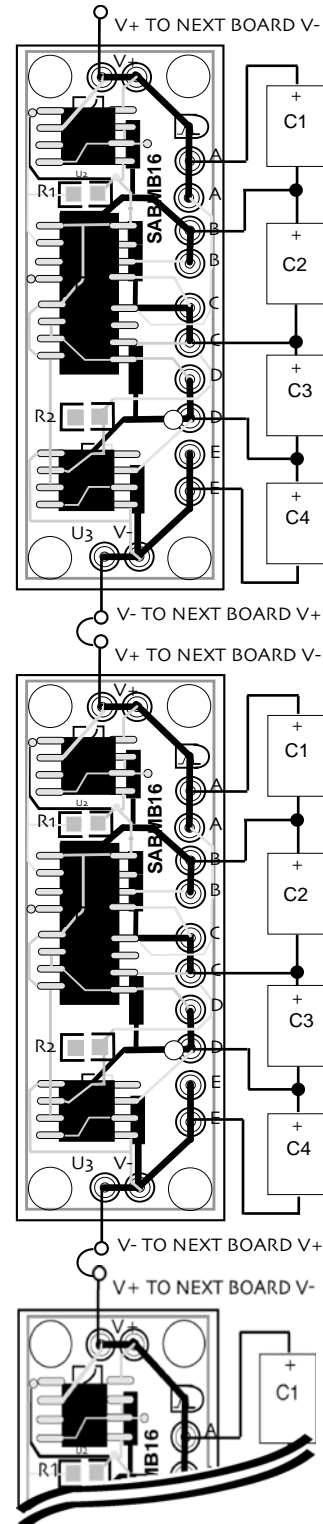

* Magnified, not to scale

SUPERCAPACITOR AUTO BALANCING PCB

SABMB16 SCHEMATIC DIAGRAM

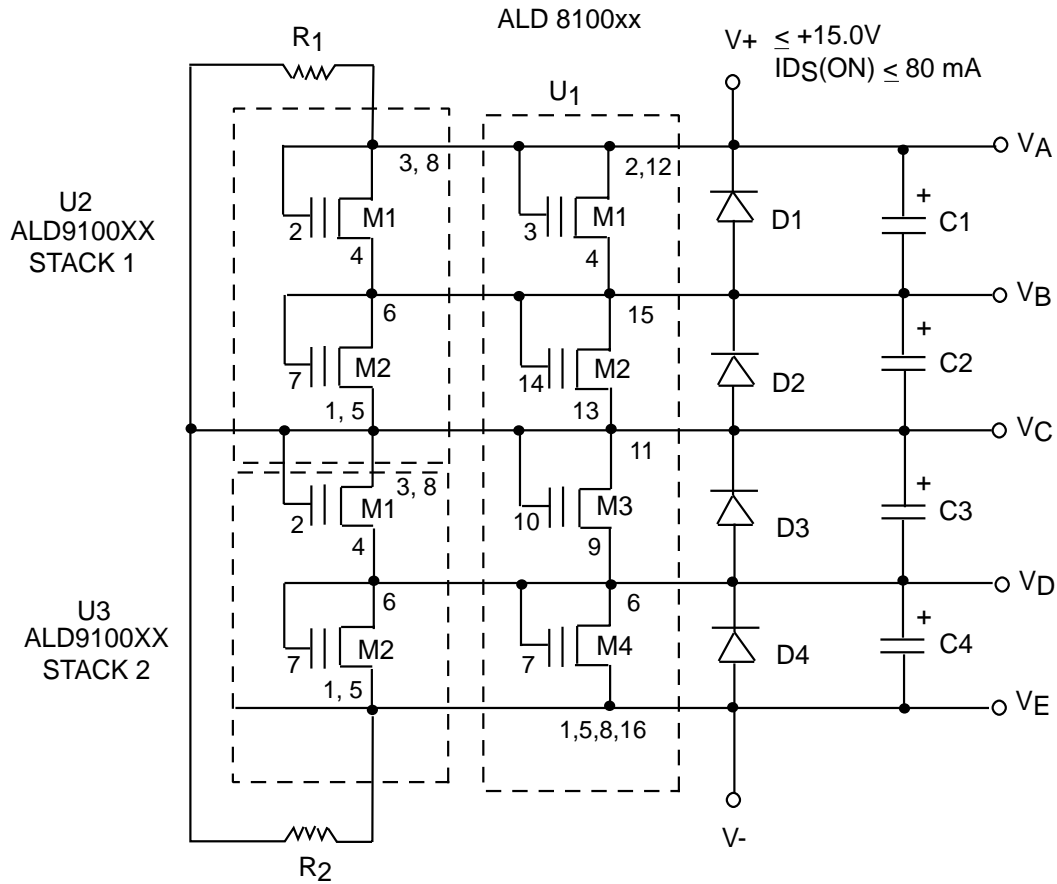

NOTES

1. R1, R2: USER SPECIFIED VALUES FROM OPEN CIRCUIT TO ZERO (0.0) OHMS
2. U1: 16L SOIC ALD8100XXSCLI
U2, U3: 8L SOIC ALD9100XXSALI
3. D1, D2, D3, D4 OPTIONAL SCHOTTKY RECTIFIER FOR REVERSE CURRENT CLAMPING (TO 277 FOOTPRINT)
4. C1, C2, C3, C4 ARE SUPERCAPACITORS EXTERNAL TO THE SABMB16 PCB

PCB PRODUCT PART NUMBERS

SABMB810016	SABMB910016
SABMB810017	SABMB910017
SABMB810018	SABMB910018
SABMB810019	SABMB910019
SABMB810020	SABMB910020
SABMB810021	SABMB910021
SABMB810022	SABMB910022
SABMB810023	SABMB910023
SABMB810024	SABMB910024
SABMB810025	SABMB910025
SABMB810026	SABMB910026
SABMB810027	SABMB910027
SABMB810028	SABMB910028